

JUNKER BUAJ 30 CNC

Categoria Rettifica
Tipo per esterni

Marca JUNKER
Modello BUAJ 30 CNC

Capacità ø300x800 mm
Anno di costruzione 2000



Specifiche tecniche

Gamba Macchine Srl

V.A.T. IT00639540988
C.F./R.I. 01581570171
REA 248813 BS
C.S. 802.165,00 €

Contatti

+39 030 831096
+39 030 8913312
offerte@gambamacchine.it

Dove siamo

Sede e Deposito 1
Via Artigiani, 32 - 25063
Gardone V.T. Brescia - Italia

Deposito 2

Via Caduti del lavoro 41, 25030
Coccaglio Brescia - Italia

CAMPO DI LAVORO	TAVOLA	CNC
Distanza punte 800 mm Altezza punte 150 mm Diametro rettificabile max 300 mm Lunghezza rettificabile max 800 mm Longitudinale (Z) 756 mm	Peso max pezzo 120 Kg Velocità traslazione 0 - 7,5 mm/min Corsa 756 mm Inclinazione +/- 8,30°	CNC FANUC210i Sistema di misura MARPOSSE9 Azionamenti FANUC
TESTA PORTAMOLA	MOLA SINISTRA	TESTA PORTAPEZZO
Potenza mandrino esterni 7,5 Kw Velocità rotazione mola esterni 300 Rpm Risoluzione (asse B) +45/-15°	Spessore fascia mola 63 mm Diametro max mola 400 mm Diametro foro 127 mm	Velocità rotazione 22/313 - 300/750 Rpm Inclinazione 90° Cono MK4
CONTROPUNTA		Peso totale macchina 2800 Kg Ingombri Macchina 300X1850X1800 mm Accessori a corredo Diamantatore Libri uso e manutenzione Sì Schemi elettrici Sì Certificazione CE Sì Carenatura COMPLETA Aspiratore fumi Sì Disponibilità PRONTA Visibile a magazzino Sì Sistema filtraggio filtro a carta 250lt.
Corsa canotto 30 mm Cono MK4		

Gamba Macchine Srl

V.A.T. IT00639540988

C.F./R.I. 01581570171

REA 248813 BS

C.S. 802.165,00 €

Contatti

+39 030 831096

+39 030 8913312

offerte@gambamacchine.it

Dove siamo**Sede e Deposito 1**

Via Artigiani, 32 - 25063

Gardone V.T. Brescia - Italia

Deposito 2

Via Caduti del lavoro 41, 25030

Coccaglio Brescia - Italia

Service instructions



1. Electrical equipment

Power requirements.....	3x400V, 50Hz
Power input, total.....	9kVA
Protection.....	3x25A
Supply lead.....	5x4 mm ² , Cu

2. Mechanical specifications

2.1. Machine

Outside dimensions.....	3000x1850x1800mm
Weight, standard version.....	2,800 kg

2.2. Workpiece

Distance between centres.....	800mm
Centre-table clearance.....	150mm
Workpiece weight between centres, max.....	120kg
Machine working accuracy.....	IT4 ISO

2.3. Wheel head

Grinding wheel, max. diameter.....	400mm
Grinding wheel, max. width.....	63mm
Grinding wheel, clamping diameter.....	127mm
Motor power.....	7.5kW
Grinding wheel, max. peripheral speed.....	45m/s
Wheel head, path of adjustment.....	300mm
Wheel head, adjustment angle.....	+45°/-15°

2.4. Work head

Spindle taper.....	MK5
Spindle, stepless speed control.....	22-313 or 300-750 r.p.m.
Work head, adjustment angle.....	90°

2.5. Tailstock

Taper.....	MK4
Tailstock barrel, stroke.....	30 mm

2.6. Longitudinal feed

Table travel.....	756 mm
Table, working travel speed.....	0 + 7.5 m/min
Top table, swivelling.....	+/-8°30'

3-3

Service instructions



2.7. Cross feed

Wheel head, feed rate.....	160 mm
----------------------------	--------

2.8. Hydraulic system

Hydraulic oil tank, capacity.....	12 l
-----------------------------------	------

2.9. Cooling system

Coolant tank, capacity.....	250 l
-----------------------------	-------

3. Axes description

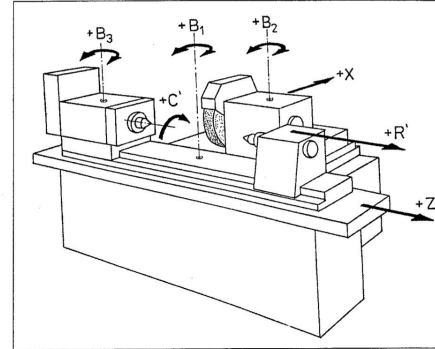

3-4

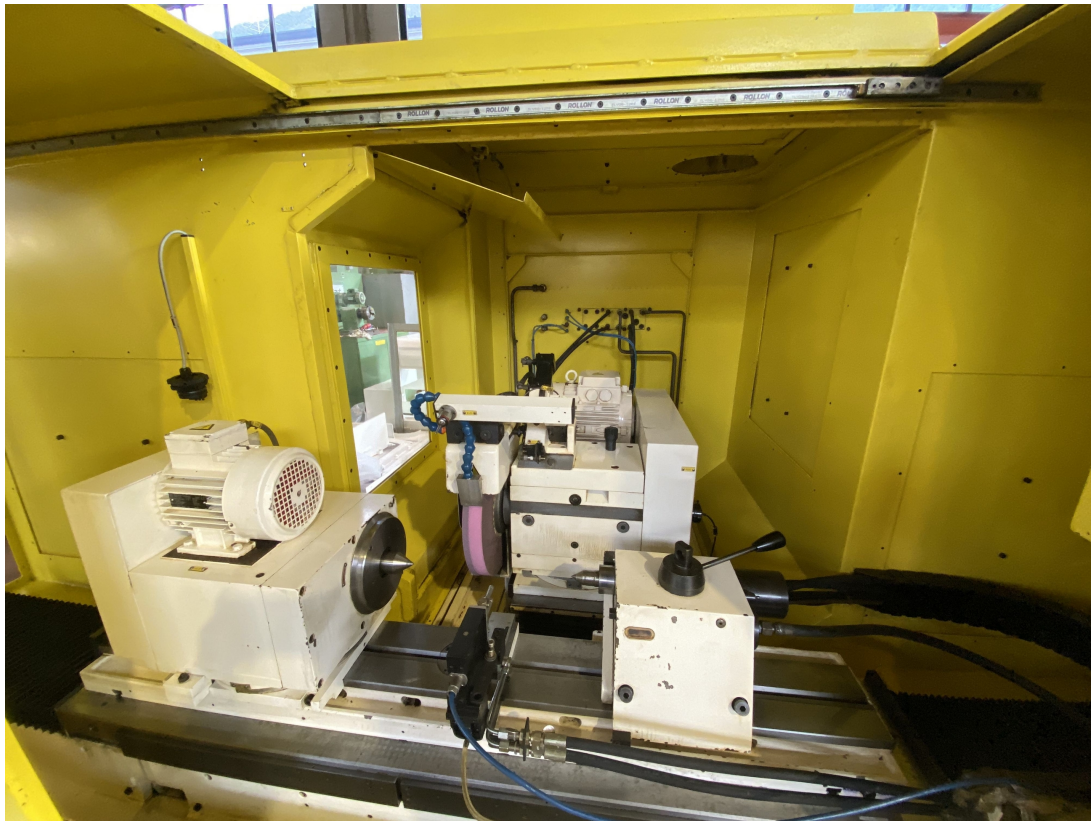

Gamba Macchine Srl

Contatti

Dove siamo

V.A.T. IT00639540988

+39 030 831096

Sede e Deposito 1

C.F./R.I. 01581570171

+39 030 8913312

Via Artigiani, 32 - 25063

REA 248813 BS

offerte@gambamacchine.it

Gardone V.T. Brescia - Italia

C.S. 802.165,00 €

Deposito 2

Via Caduti del lavoro 41, 25030

Coccaglio Brescia - Italia

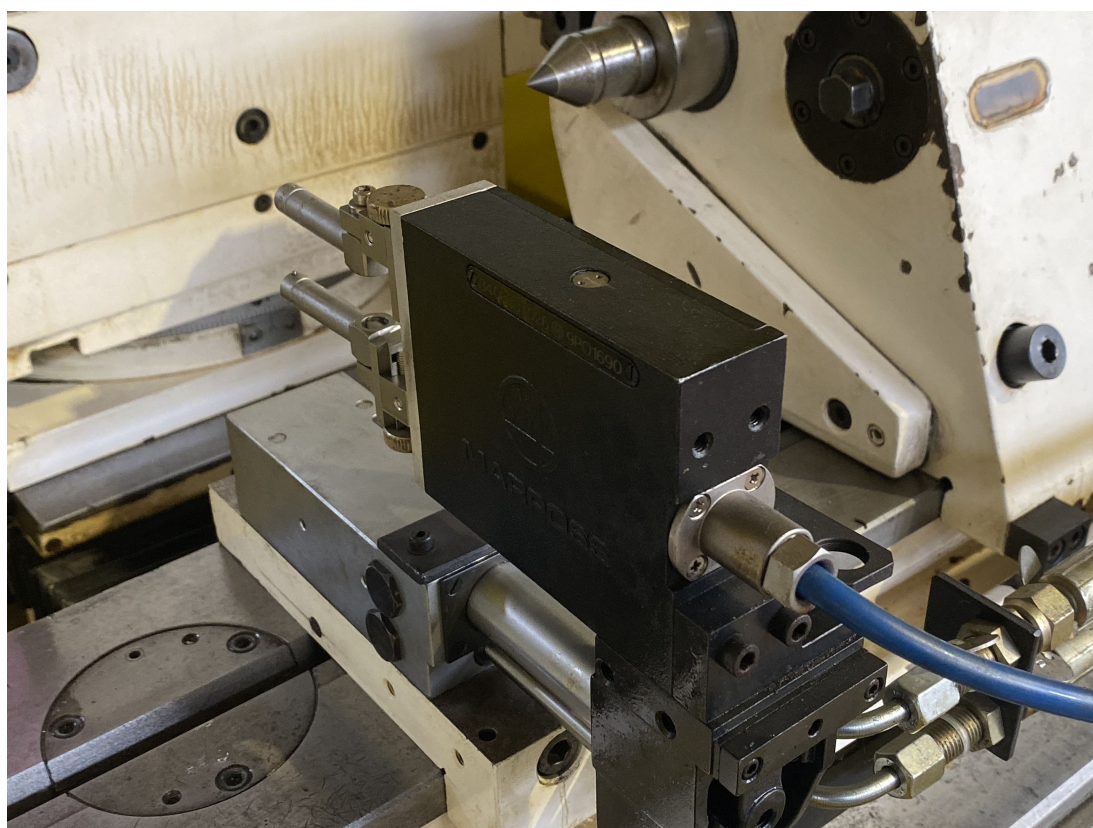

Gamba Macchine Srl

V.A.T. IT00639540988

C.F./R.I. 01581570171

REA 248813 BS

C.S. 802.165,00 €

Contatti

+39 030 831096

+39 030 8913312

offerte@gambamacchine.it

Dove siamo

Sede e Deposito 1

Via Artigiani, 32 - 25063

Gardone V.T. Brescia - Italia

Deposito 2

Via Caduti del lavoro 41, 25030

Coccaglio Brescia - Italia

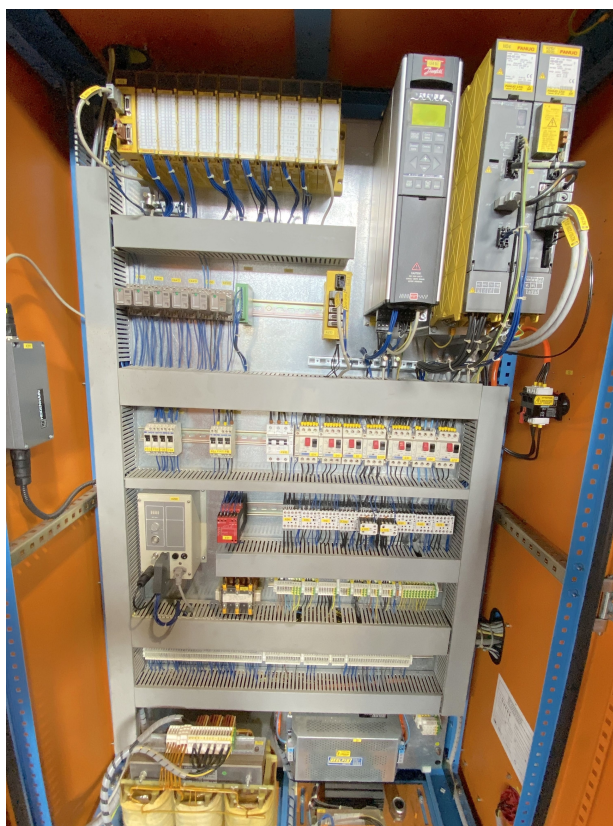

Gamba Macchine Srl

V.A.T. IT00639540988

C.F./R.I. 01581570171

REA 248813 BS

C.S. 802.165,00 €

Contatti

+39 030 831096

+39 030 8913312

offerte@gambamacchine.it

Dove siamo

Sede e Deposito 1

Via Artigiani, 32 - 25063

Gardone V.T. Brescia - Italia

Deposito 2

Via Caduti del lavoro 41, 25030

Coccaglio Brescia - Italia

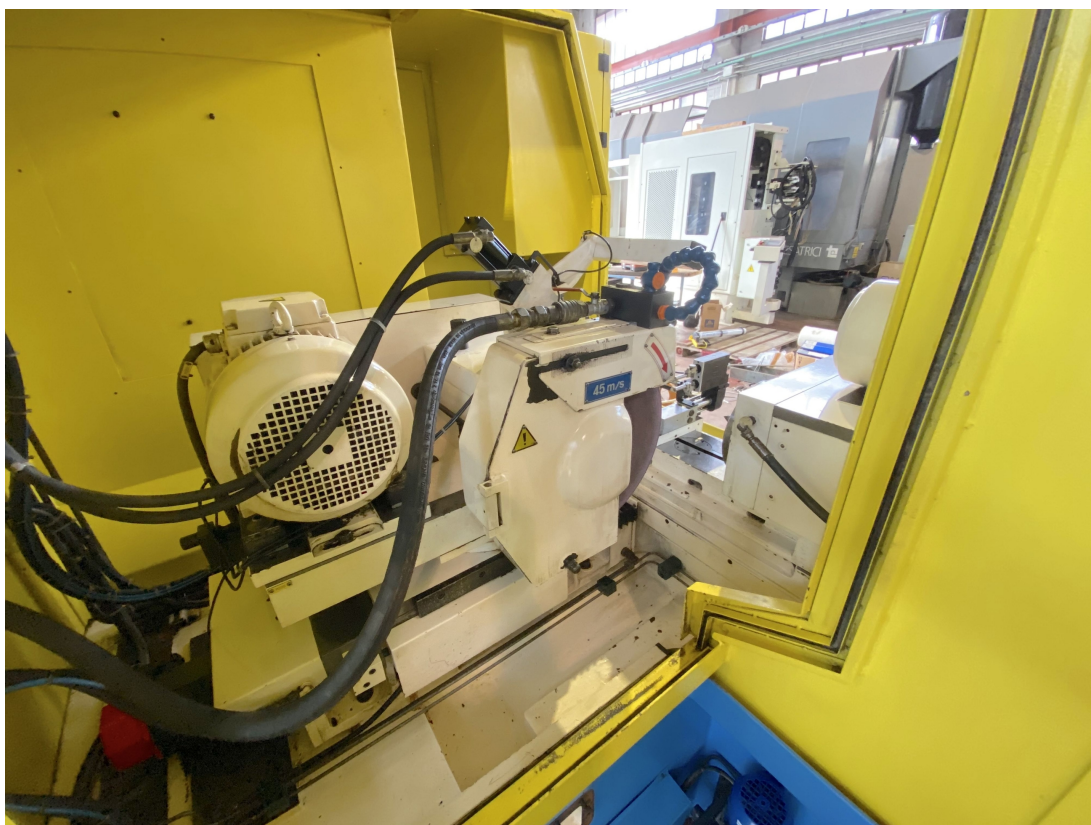

Gamba Macchine Srl

V.A.T. IT00639540988

C.F./R.I. 01581570171

REA 248813 BS

C.S. 802.165,00 €

Contatti

+39 030 831096

+39 030 8913312

offerte@gambamacchine.it

Dove siamo

Sede e Deposito 1

Via Artigiani, 32 - 25063

Gardone V.T. Brescia - Italia

Deposito 2

Via Caduti del lavoro 41, 25030

Coccaglio Brescia - Italia



Gamba Macchine Srl

V.A.T. IT00639540988

C.F./R.I. 01581570171

REA 248813 BS

C.S. 802.165,00 €

Contatti

+39 030 831096

+39 030 8913312

offerte@gambamacchine.it

Dove siamo

Sede e Deposito 1

Via Artigiani, 32 - 25063

Gardone V.T. Brescia - Italia

Deposito 2

Via Caduti del lavoro 41, 25030

Coccaglio Brescia - Italia

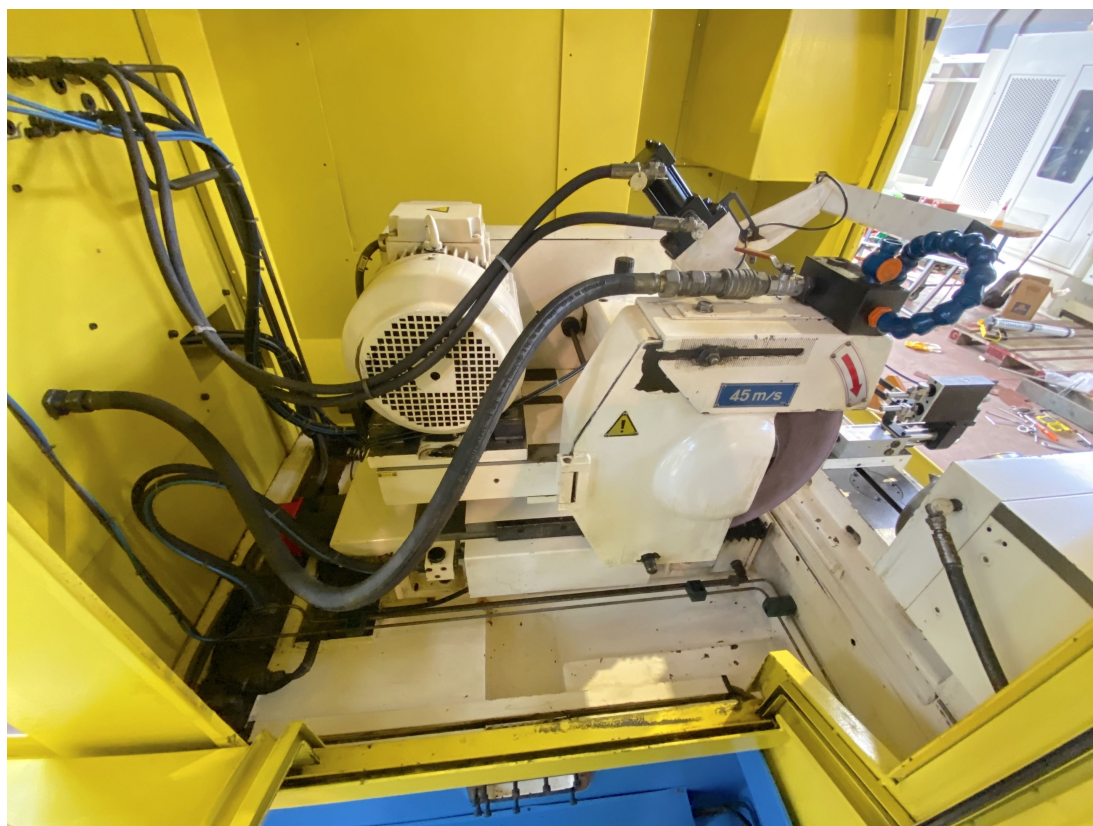

Gamba Macchine Srl

V.A.T. IT00639540988

C.F./R.I. 01581570171

REA 248813 BS

C.S. 802.165,00 €

Contatti

+39 030 831096

+39 030 8913312

offerte@gambamacchine.it

Dove siamo

Sede e Deposito 1

Via Artigiani, 32 - 25063

Gardone V.T. Brescia - Italia

Deposito 2

Via Caduti del lavoro 41, 25030

Coccaglio Brescia - Italia



Gamba Macchine Srl

V.A.T. IT00639540988

C.F./R.I. 01581570171

REA 248813 BS

C.S. 802.165,00 €

Contatti

+39 030 831096

+39 030 8913312

offerte@gambamacchine.it

Dove siamo

Sede e Deposito 1

Via Artigiani, 32 - 25063

Gardone V.T. Brescia - Italia

Deposito 2

Via Caduti del lavoro 41, 25030

Coccaglio Brescia - Italia



Gamba Macchine Srl

V.A.T. IT00639540988

C.F./R.I. 01581570171

REA 248813 BS

C.S. 802.165,00 €

Contatti

+39 030 831096

+39 030 8913312

offerte@gambamacchine.it

Dove siamo

Sede e Deposito 1

Via Artigiani, 32 - 25063

Gardone V.T. Brescia - Italia

Deposito 2

Via Caduti del lavoro 41, 25030

Coccaglio Brescia - Italia



Gamba Macchine Srl

V.A.T. IT00639540988

C.F./R.I. 01581570171

REA 248813 BS

C.S. 802.165,00 €

Contatti

+39 030 831096

+39 030 8913312

offerte@gambamacchine.it

Dove siamo

Sede e Deposito 1

Via Artigiani, 32 - 25063

Gardone V.T. Brescia - Italia

Deposito 2

Via Caduti del lavoro 41, 25030

Coccaglio Brescia - Italia